

# GDF36-18Z/0.75 Outline diagram

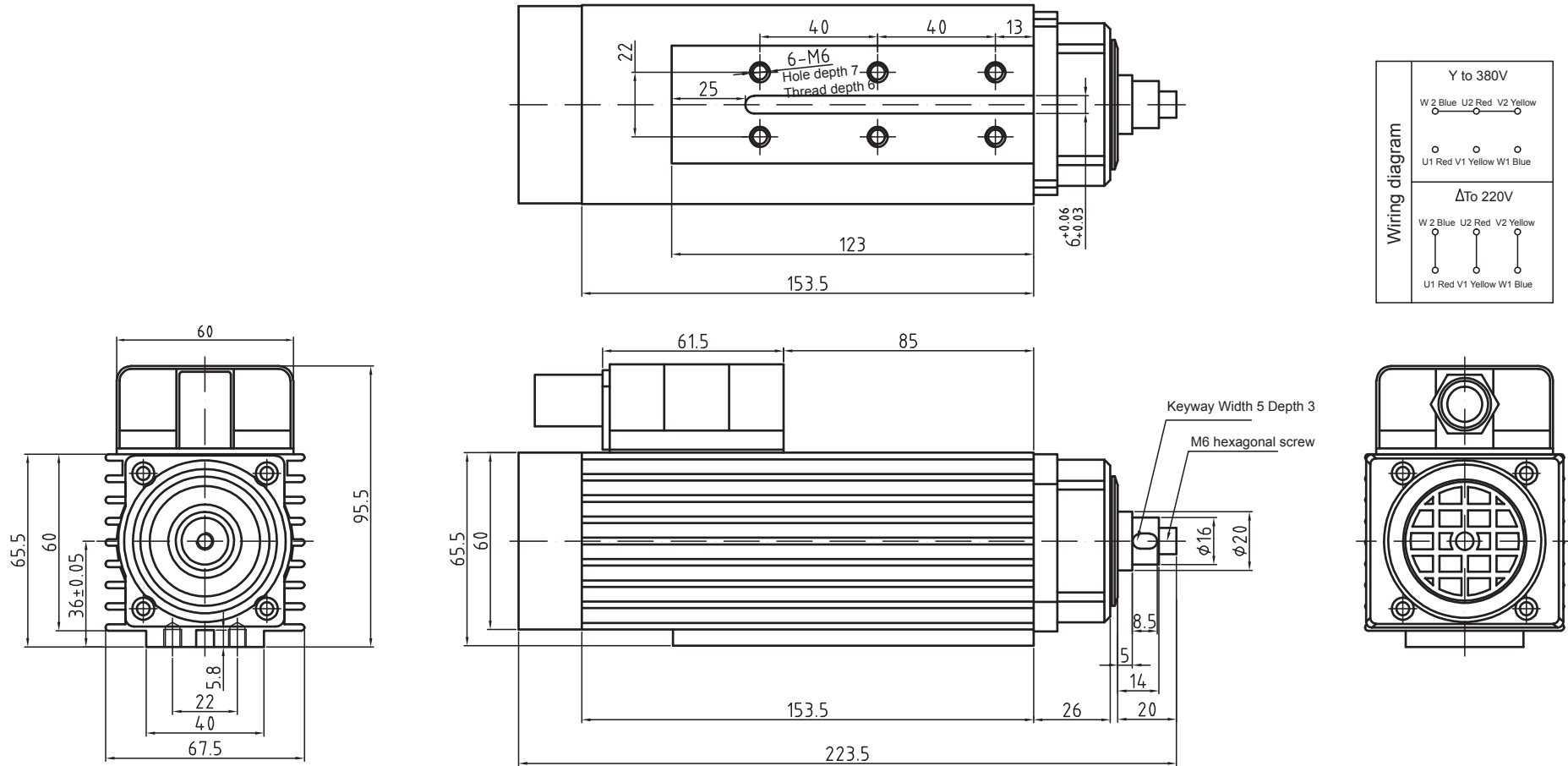

## GDF36-18Z/0.75

Power 0.75 kw  
 Voltage Y to 380V/Δ to 220V  
 Current 2.3 A/3.9A  
 Frequency 300 Hz  
 Rotating speed 18000 r/min

Weight: 2.8KG  
 Shaft end connection: cylindrical key connection  
 Cooling method: air cooling  
 Bearing lubrication method: grease lubrication  
 High-precision angular contact ball bearing: 1×6005 1×6000/P4  
 Rotating direction: left thread L/right thread R rotating directions, used in pair!

Special attention: thread locking adhesive shall be applied or the spring washer shall be added to prevent the looseness during the installation of the fastening screw!