

GDL60-24Z/6.0 380V Profile Drawing

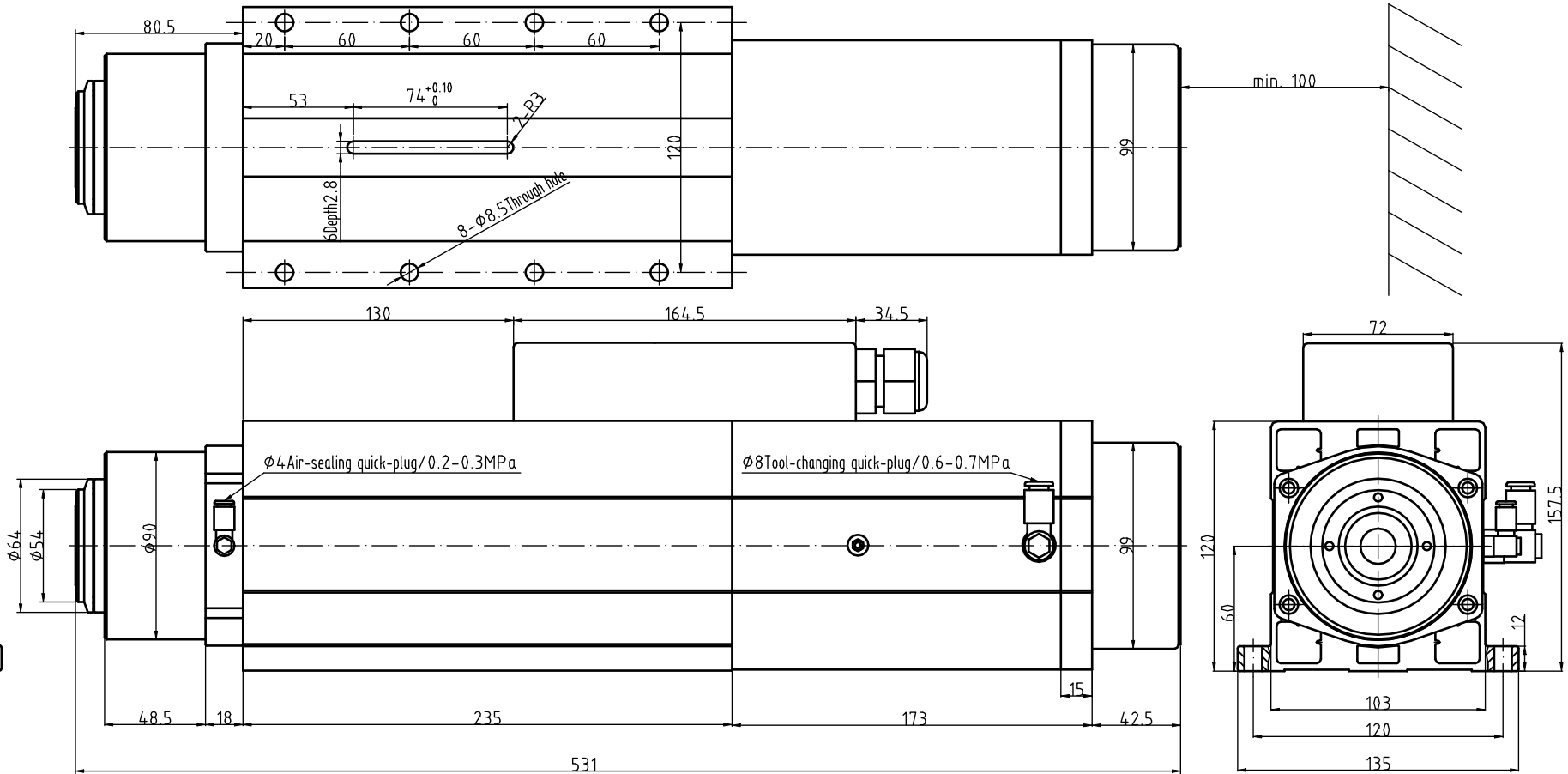

Rated Power: 6.0Kw
 Rated Voltage: 380V
 Rated Rotation: 24000r/min
 Rated Frequency: 800Hz
 Rated Current: 12.5A
 Number of Pole: 4P
 Bearing of Grease Type: 2X7008C 2X7006C
 Rotating Direction: Counterclockwise viewed from
 the end of spindle extension
 Cooling Method: 24VDC DC fan cooling
 Tool Holder: ISO30
 Weight: Approx 21kg

